

15CX1000

High Output Coaxial Transducer

Key Features

- 98dB LF / 107,5dB HF SPL 1W/1m average sensitivity
- 100 mm (4") Interleaved Sandwich Voice LF coil (ISV)
- 850W LF - 200 W HF power handling
- Copper shorting ring for constant power transfer
- 1,4" exit HF neodymium compression driver
- 75 mm (3") HF edgewound voice coil with high temperature ferrofluid
- FEA optimized coupling horn profile
- 70 degrees nominal conical dispersion
- Suitable for very compact enclosures and stage monitors
- Weather protected cone and plates for outdoor usage



General Description

The 15CX1000 is a 15" – 1.4" coaxial transducer designed for use in compact reflex enclosures and stage monitors as small as 50 lt with a nominal dispersion of 70 degrees.

The low profile, carbon fiber reinforced, smooth curvilinear LF cone provides smooth response within its intended frequency range and exceptional strength, with maximum reliability under high mechanical stress.

The state-of-the-art 100 mm (4 in) LF voice coil employs our Interleaved Sandwich Voice coil (ISV) technology, in which a high strength fiberglass former carries windings on both the outer and inner surfaces. This results in a balanced coil with a uniform distribution of mass and motive energy and an extremely linear motor assembly.

A copper-shortening ring on the LF section plates has been adopted to reduce inductance and improve transient response. Hence, the intermodulation distortion figure has been heavily improved.

The neodymium 1.4" exit compression driver adopted is our ND1480 model, which has been given further thermal power handling capacity by adding high temperature ferrofluid in the gap. This has improved the thermal exchange properties even more.

The HF driver diaphragm assembly, using a high strength, high temperature treated Nomex voice coil former joined directly to the titanium diaphragm on its upper bend edge, assures extended frequency energy transfer. This improves linearity and shows unparalleled reliability when compared with a usual straight former joint.

The HF motor structure utilizes a precisely machined coherent phase plug with 3 circumferential slots. A copper ring on the pole piece reduces the inductance figure of frequencies above 10 kHz, improving phase and impedance linearisation.

A specific design has been chosen by Eighteen Sound engineers in order to maximize the cone's profile coupling.

Due to the widespread use of high power audio systems at outdoor events, the ability to perform in adverse weather conditions is an additional key feature of the 15CX1000. This has been achieved using exclusive cone and magnet plate treatment processes which increase resistance against corrosion and make the cone water repellent.

022158CX10 8 Ohm

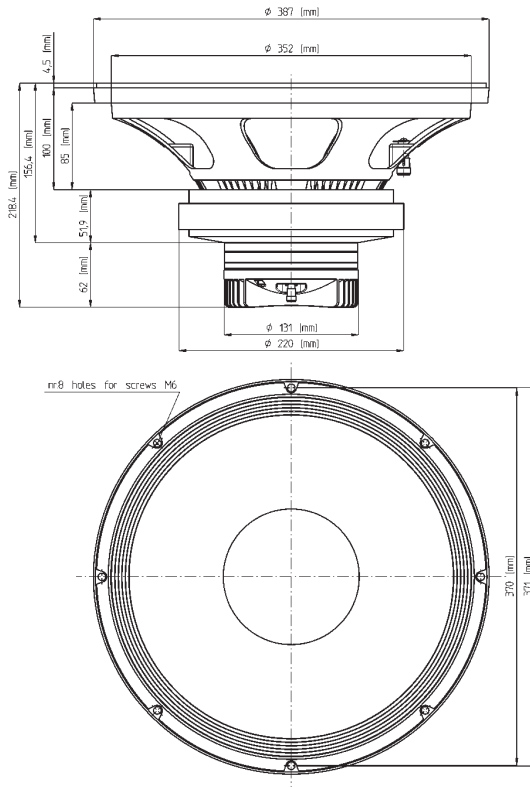

FERRITE LF-MB-MF TRANSDUCERS

15CX1000

High Output Coaxial Transducer

LF GENERAL SPECIFICATIONS

NOMINAL DIAMETER	380 mm (15 in)
RATED IMPEDANCE	8 Ohm
AES POWER	850 W
PROGRAM POWER (1)	1000 W
PEAK POWER (2)	3000 W
SENSITIVITY (3)	98 dB
FREQUENCY RANGE (4)	45 ÷ 5100 Hz
POWER COMPRESSION @-10DB (5)	0,9 dB
POWER COMPRESSION @-3DB	2,1 dB
POWER COMPRESSION @0DB	3,8 dB
MAX RECOMM. FREQUENCY	1000 Hz
RECOMM. ENCLOSURE VOLUME	70 ÷ 150 lt. (2,47 ÷ 5,3 cuft)
MINIMUM IMPEDANCE	6 Ohm at 25°C
MAX PEAK TO PEAK EXCURSION	39 mm (1,53 in)
VOICE COIL DIAMETER	100 mm (4 in)
VOICE COIL WINDING MATERIAL	aluminum
SUSPENSION	Triple roll, Polycotton
CONE	Curvilinear, Paper

HF GENERAL SPECIFICATIONS

D.C. RESISTANCE	6,2 Ohm
AES POWER (6)	100W above 1,2 kHz
PROGRAM POWER (7)	200W above 1,2 kHz
SENSITIVITY (8)	107,5 dB
FREQUENCY RANGE	0,5 kHz ÷ 20 kHz
RECOMMENDED XOVER FREQUENCY	1 kHz 12dB/oct
VOICE COIL DIAMETER	74,6 mm (3 in)

LF THIELE SMALL PARAMETERS (9)

Fs	48 Hz
Re	5,5 Ohm
Sd	0,0855 sq.mt. (132,5 sq.in.)
Qms	6
Qes	0,32
Qts	0,31
Vas	132,5 lt. (4,66 cuft)
Mms	85 gr. (0,19 lb)
BL	21 Tm
Mathematical Xmax (10)	±6 mm (±0,24 in)
Le (1kHz)	1,5 mH
Ref. Efficiency 1W@1m (half space)	98,4 dB

MOUNTING INFORMATION

Overall Ø	387 mm (15,23 in)
N. of mounting holes	8
Mounting holes Ø	7,15 mm (0,28 in)
Bolt circle Ø	370-371 mm (14,55-14,6 in)
Front mount baffle cutout Ø	353 mm (13,9 in)
Rear mount baffle cutout Ø	357 mm (14,06 in)
Total depth	218,4 mm (8,6 in)
Flange and gasket thickness	19,5 mm (0,76 in)
Net weight	14,4 kg (31,68 lb)
Shipping weight	15 kg (34,1 lb)
CardBoard Packaging dim.	405 x 405 x 230 mm (15,94 x 15,94 x 9,05 in)

FREQUENCY RESPONSE CURVE OF 15CX1000 MADE ON 125 LT ENCLOSURE TUNED 50HZ IN FREE FIELD (4PI) ENVIRONMENT. ENCLOSURE CLOSES THE REAR OF THE DRIVER. THIN LINE REPRESENTS HIGH FREQUENCY RESPONSE.

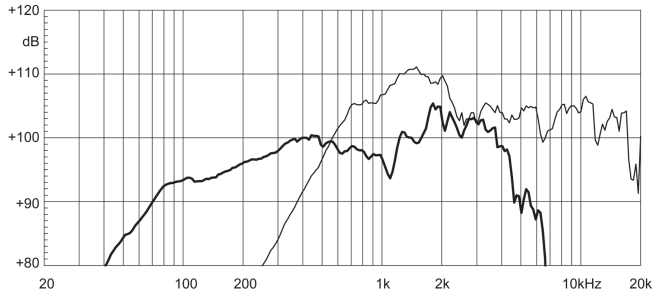

FREE AIR IMPEDANCE MAGNITUDE CURVE

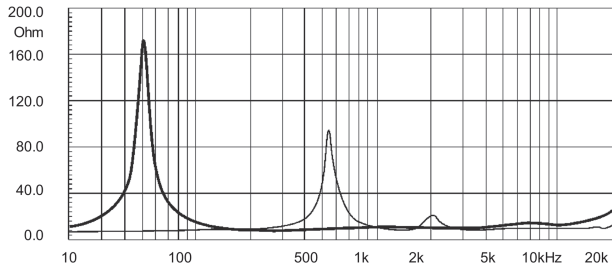

NOTES

- (1) Program power rating is measured in 125 lit enclosure tuned 50Hz using a 40 - 400Hz band limited pink noise test signal with 50% duty cycle, applied for 2 hours.
- (2) The peak power rating represents the maximum permitted instantaneous peak power level over a maximum period of 10ms which will be withstood by the loudspeaker without damage.
- (3) Sensitivity represents the averaged value of acoustic output as measured on the forward central axis of cone, at distance 1m from the baffle panel, when connected to 2,83V sine wave test signal swept between 100Hz and 500Hz with the test specimen mounted in the same enclosure as given for (1) above.
- (4) Frequency range is given as the band of frequencies delineated by the lower and upper limits where the output level drops by 10 dB below the rated sensitivity in half space environment.
- (5) Power compression represents the loss of sensitivity for the specified power, measured from 50-500 Hz, after a 5 min pink noise preconditioning test at the specified power.
- (6) AES power rating is measured with a pink noise input having a 6 dB crest factor for two hours duration, per AES standard. Power calculated on minimum impedance.
- (7) Program power is defined as 3 dB greater than AES rating, and is a conservative expression of the transducer ability to handle music program material.
- (8) Sensitivity is measured on 1W input on rated impedance at 1m on axis from the mouth of the woofer and averaged in 3kHz band.
- (9) Thiele - Small parameters are measured after the test specimen has been conditioned by 500 W AES power and represent the expected long term parameters after a short period of use.
- (10) Linear Math. Xmax is calculated as $(Hvc-Hg)/2 + Hg/4$ where Hvc is the coil depth and Hg is gap depth.

Eighteen Sound engages in research and product improvement. New materials and design refinements can be introduced into existing products without notice.