

8M400

High Output Midrange Transducer

Key Features

- 100,5 dB SPL 1W / 1m average sensitivity
- 51 mm (2 in) Interleaved Sandwich Voice coil (ISV)
- 250 Watt AES power handling
- Improved heat dissipation via unique basket design
- Copper ring to linearize impedance curve
- Suitable for high quality midrange applications



General Description

The 8M400 is a high power, high output, 200 mm (8 in) midrange for high level professional use. The excellent sound quality has been achieved as a result of extensive research on mid frequencies intelligibility. The 8M400 has been designed for use as a midrange in both horn and direct radiation, closer or reflex enclosures, as small as 3 lt.

The curvilinear cone, made with a high damping wood pulp, has been designed to achieve the best possible linearity within its frequency range. The in-house developed cone treatment is a humidity repellent and also dampens the bell mode resonance significantly.

The 51 mm (2 in) ISV aluminum voice coil assembly is wound on a strong fiberglass former to improve force transmission and power handling.

ISV technology is based on a high strength fiberglass former with half the coil wound on the outside and half on the inside and bonded together using unique high temperature resin adhesives.

The powerful magnet assembly assures high flux concentration. The force factor and power handling are at an optimum level. The direct contact between the finned basket and the magnetic structure significantly improves thermal connection and heat dissipation, further increasing power handling and lowering power compression.

The copper shorting ring on the pole piece reduces inductance and improves transient response and phase control in the mid frequencies.

0220887410 8 Ohm

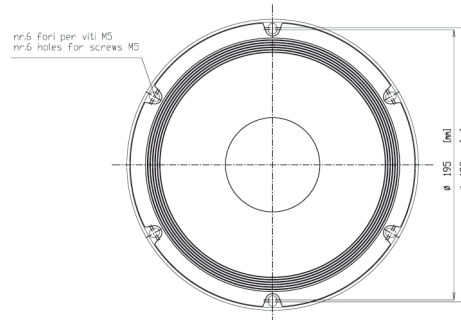
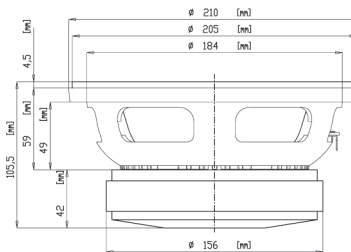

FERRITE LF-MB-MF TRANSDUCERS

8M400

High Output Midrange Transducer

GENERAL SPECIFICATIONS

NOMINAL DIAMETER	200 mm (8 in)
RATED IMPEDANCE	8 Ohm
AES POWER	250 W
PROGRAM POWER (1)	320 W
PEAK POWER (2)	650 W
SENSITIVITY (3)	100,5 dB
FREQUENCY RANGE (4)	120 ÷ 6100 Hz
POWER COMPRESSION @-10DB (5)	0,5 dB
POWER COMPRESSION @-3DB	1,6 dB
POWER COMPRESSION @FULL POWER	2,7 dB
MAX RECOMM. FREQUENCY	4000 Hz
RECOMM. ENCLOSURE VOLUME	2 ÷ 10 lt. (0,07 ÷ 0,35 cuft)
MINIMUM IMPEDANCE	6,5 Ohm at 25°C
MAX PEAK TO PEAK EXCURSION	13 mm (0,51 in)
VOICE COIL DIAMETER	51 mm (2 in)
VOICE COIL WINDING MATERIAL	aluminum
SUSPENSION	M-roll, Polycotton
CONE	Curvilinear, Paper

THIELE SMALL PARAMETERS (6)

Fs	90 Hz
Re	5,2 Ohm
Sd	0,0227 sq.mt. (35,19 sq.in.)
Qms	6,2
Qes	0,28
Qts	0,27
Vas	16,2 lt. (0,57 cuft)
Mms	14 gr. (0,03 lb)
BL	12,2 Tm
Linear Mathematical Xmax (7)	± 3 mm (±0,12 in)
Le (1kHz)	0,95 mH
Ref. Efficiency 1W@1m (half space)	98,1 dB

MOUNTING INFORMATION

Overall diameter	210 mm (8,27 in)
N. of mounting holes	6
Mounting holes diameter	6 mm (0,23 in)
Bolt circle diameter	195 - 198 mm (7,68 - 7,80 in)
Front mount baffle cutout ø	186 mm (7,32 in)
Rear mount baffle cutout ø	184 mm (7,24 in)
Total depth	105,5 mm (4,15 in)
Flange and gasket thickness	14,5 mm (0,57 in)
Net weight	4,5 kg (9,93 lb)
Shipping weight	4,8 kg (10,6 lb)
CardBoard Packaging dimensions	235 x 235 x 150 mm (9,25 x 9,25 x 5,91 in)

FREQUENCY RESPONSE CURVE OF 8M400 MADE ON 3 LIT. CLOSED ENCLOSURE IN FREE FIELD (4PI). ENCLOSURE CLOSES THE REAR OF THE DRIVER. THE THIN LINE REPRESENTS 45 DEG. OFF AXIS FREQUENCY RESPONSE

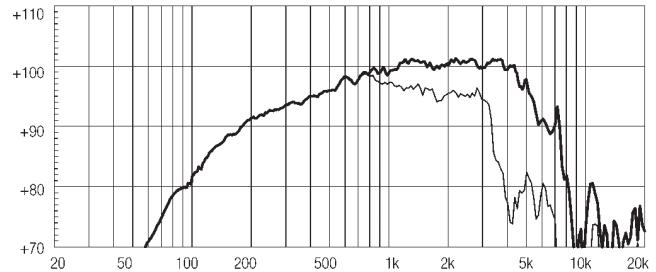

FREE AIR IMPEDANCE MAGNITUDE CURVE

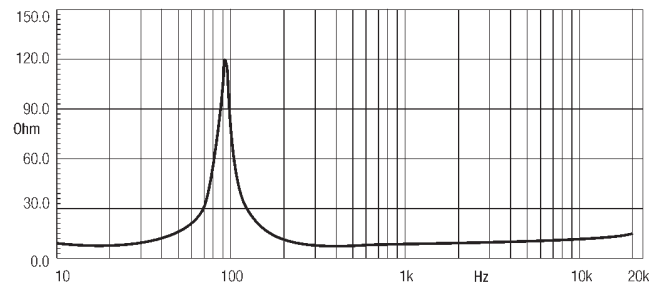

NOTES

- (1) Program power rating is measured in 3 lit closed enclosure using a 100 - 2500Hz band limited pink noise test signal with 50% duty cycle, applied for 2 hours.
- (2) The peak power rating represents the maximum permitted instantaneous peak power level over a maximum period of 10ms which will be withstood by the loudspeaker without damage.
- (3) Sensitivity represents the averaged value of acoustic output as measured on the forward central axis of cone, at distance 1m from the baffle panel, when connected to 2,83V sine wave test signal swept between 500Hz and 2500Hz with the test specimen mounted in the same enclosure as given for (1) above.
- (4) Frequency range is given as the band of frequencies delineated by the lower and upper limits where the output level drops by 10 dB below the rated sensitivity in half space environment.
- (5) Power compression represents the loss of sensitivity for the specified power, measured from 100-1000 Hz, after a 5 min pink noise preconditioning test at the specified power.
- (6) Thiele - Small parameters are measured after the test specimen has been conditioned by 250 W AES power and represent the expected long term parameters after a short period of use.
- (7) Linear Math. Xmax is calculated as $(Hvc-Hg)/2 + Hg/4$ where Hvc is the coil depth and Hg is the gap depth.

Eighteen Sound engages in research and product improvement. New materials and design refinements can be introduced into existing products without notice.