

MSF061.50

Lavoce

6.5" MIDRANGE

FERRITE MAGNET
STEEL BASKET DRIVER



- 1.5 INCH COPPER VOICE COIL
- 95 dB/SPL SENSITIVITY
- 200 WATT PROGRAM POWER HANDLING
- FEM OPTIMIZED MOTOR AND SUSPENSIONS
- RESONANCE FREE AND HEAVY DUTY BASKET DESIGN

GENERAL SPECIFICATIONS

Nominal diameter	mm (in.)	165 (6.5)
Nominal impedance	Ω	8
Minimum impedance	Ω	7,1
Program power (1)	W	200
AES Power rating (2)	W	100
Sensitivity (3)	dB	95
Frequency range	Hz	500 ÷ 5000
Voice coil diameter	mm (in.)	38 (1.5)
Chassis material	Steel	
Magnet material	Ferrite	
Magnet dimensions OD x ID x h	mm (in.)	100 x 45 x 15 (3.94 x 1.77 x 0.59)
Coil material	Copper	
Former material	Polyimide	
Cone material	Water Proof Treated Paper	
Surround material	Paper	
Xmax (4)	mm (in.)	2 (0.08)
Xmech (5)	mm (in.)	4,5 (0.18)
Gap height	mm (in.)	6 (0.24)
Voice coil winding height	mm (in.)	7 (0.28)
Driver displacement volume	l (ft ³)	0,786 (0.028)

SMALL SIGNAL PARAMETERS

DC resistance	Re	Ohm	5,9
Resonance frequency	Fs	Hz	526
Moving mass	Mms	g (oz)	9,2 (0.32)
Compliance	Cms	mm/N	0,01
Force factor	BxL	N/A	8,2
Mechanical Q-factor	Qms		15,8
Electrical Q-factor	Qes		2,69
Total Q-factor	Qts		2,3
Equivalent air volume	Vas	l (ft ³)	0,28 (0.009)
Voice coil Inductance	Le	mH	0,41
Diaphragm area	Sd	cm ² (in. ²)	143 (22.17)
Reference efficiency	Eta 0	%	1,51

SHIPPING INFORMATION

Net weight	kg (lb.)	1,4 (3.1)
Multipack size (8)	mm (in.)	410 x 382 x 183 (16.1 x 15 x 7.2)
Multipack weight	kg (lb.)	12,9 (28.4)

FREQUENCY RESPONSE

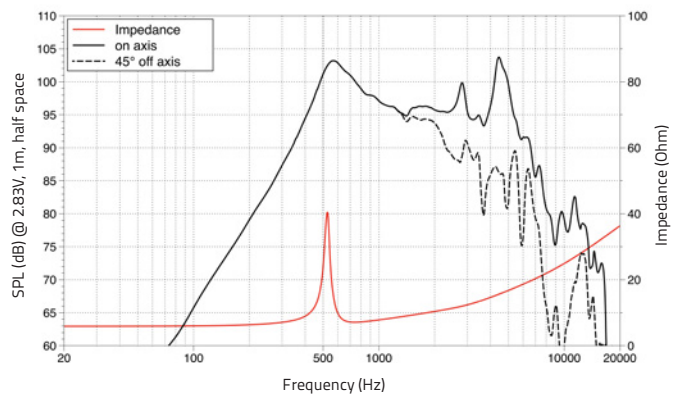

DIMENSIONS mm (in.)

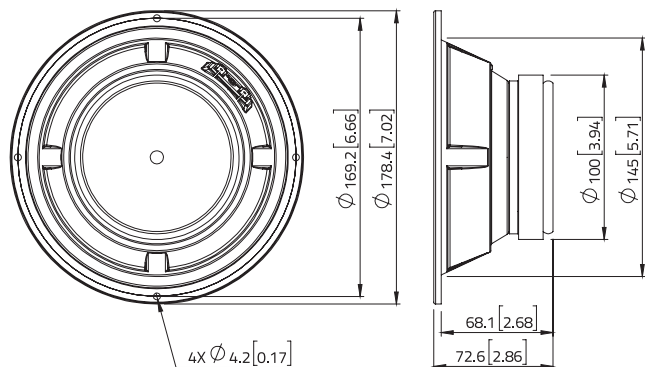

(1) Program power is defined as 3 dB greater than AES Power. (2) Tested for two hours using a continuous, band-limited pink noise signal as per AES 2-1984 Rev. 2003. Loudspeaker tested in free air. (3) From T/S parameters, measured with Klippel DA LPM module. (4) The Xmax is calculated as: $(Hvc - Hg)/2 + Hg/4$. Hvc is the voice coil height and Hg the gap height. (5) The Xmech is calculated as: $(Hvc - Hg)/2 + (Hg - 2)$. Hvc is the voice coil height and Hg the gap height. (6) Thiele-Small parameters are measured after preconditioning: a) at 20°C - 22°C, 50% humidity for 2 hours; b) by Klippel LSI measurement.

All specifications subject to change without notice_C.a

