

SSF082.00L

Lavoce

8" SUBWOOFER

FERRITE MAGNET
STEEL BASKET DRIVER



- 2 INCH CCAW VOICE COIL
- 87 dB/SPL SENSITIVITY
- 700 WATT PROGRAM POWER HANDLING
- LONG THROW DESIGN
- 29 mm (1.1 INCH) PEAK TO PEAK MAXIMUM EXCURSION
- FEM OPTIMIZED MOTOR AND SUSPENSIONS
- RESONANCE FREE AND HEAVY DUTY BASKET DESIGN
- OPTIMIZED COOLING SYSTEM
- RUBBER SURROUND MATERIAL

GENERAL SPECIFICATIONS

Nominal diameter	mm (in.)	200 (8)
Nominal impedance	Ω	8
Minimum impedance	Ω	6,7
Program power (1)	W	700
AES Power rating (2)	W	350
Sensitivity (3)	dB	87
Frequency range	Hz	50 ÷ 500
Voice coil diameter	mm (in.)	51 (2)
Chassis material	Steel	
Magnet material	Ferrite	
Magnet dimensions OD x ID x h	mm (in.)	140 x 62 x 20 (5.5 x 2.4 x 0.79)
Coil material	CCAW	
Former material	Glass fiber	
Cone material	Water Proof Treated Paper	
Surround material	Rubber	
Xmax (4)	mm (in.)	9 (0.35)
Xmech (5)	mm (in.)	14,5 (0.55)
Gap height	mm (in.)	10 (0.39)
Voice coil winding height	mm (in.)	23 (0.09)
Driver displacement volume	l (ft ³)	1 (0.03)

SMALL SIGNAL PARAMETERS

DC resistance	Re	Ohm	5,2
Resonance frequency	Fs	Hz	50
Moving mass	Mms	g (oz)	66,3 (2.34)
Compliance	Cms	mm/N	0,14
Force factor	BxL	N/A	14,7
Mechanical Q-factor	Qms		9,9
Electrical Q-factor	Qes		0,51
Total Q-factor	Qts		0,50
Equivalent air volume	Vas	l (ft ³)	9,5 (0.34)
Voice coil Inductance	Le	mH	2,5
Diaphragm area	Sd	cm ² (in. ²)	216 (33.5)
Reference efficiency	Eta 0	%	0,24

SHIPPING INFORMATION

Net weight	kg (lb.)	4,1 (9)
Multipack size (1)	mm	260 x 260 x 166
W x D x H	(in.)	(10.2 x 10.2 x 6.5)
Multipack weight	kg (lb.)	4,8 (10.5)

FREQUENCY RESPONSE

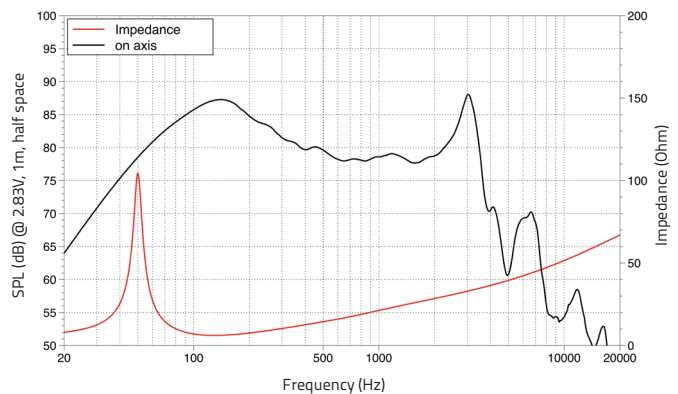

DIMENSIONS mm (in.)

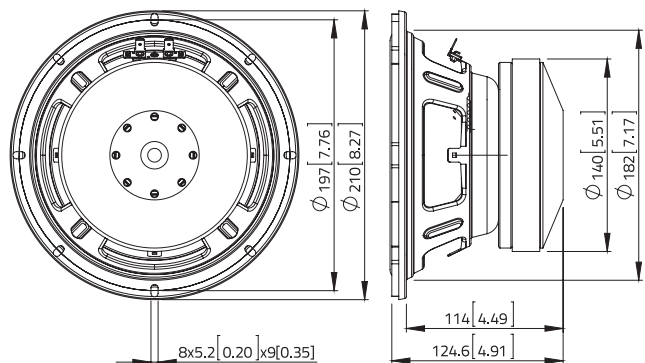

(1) Program power is defined as 3 dB greater than AES Power. (2) Tested for two hours using a continuous, band-limited pink noise signal as per AES 2-1984 Rev. 2003. Loudspeaker tested in free air. (3) From T/S parameters, measured with Klippel DA LPM module. (4) The Xmax is calculated as: $(Hvc - Hg)/2 + Hg/4$. Hvc is the voice coil height and Hg the gap height. (5) The Xmech is calculated as: $(Hvc - Hg)/2 + (Hg - 2)$. Hvc is the voice coil height and Hg the gap height. (6) Thiele-Small parameters are measured after preconditioning: a) at 20°C - 22°C, 50% humidity for 2 hours; b) by Klippel LSI measurement.

All specifications subject to change without notice_B.a

