



1040

Nominal Diameter	6.5" / 17 cm
Rated Impedance	8
Sensitivity	95.5 dB SPL
Power Handling Capacity	160 W AES
SPL max (continuous)	114 dB SPL
Usable frequency range	300 - 5000 Hz
Speaker net mass	2.15 kg

6.5 inches midrange driver



Architecture highlights :

- Midrange unit with critical damping diaphragm
- Ultra light vented CCAR voice coil
- Natural convection Intercooler System
- Flat foam surround

Motor architecture

Magnet material	-	Fe
Voice coil diameter	mm	38
Voice coil length	mm	8
Air gap height	mm	6

Typical characteristics

Rated impedance	Z	Ω	8
Half space sensitivity (1W@1m)	-	dB SPL	95.5
Usable freq. range	-	Hz	300 - 5000
Power handling capacity (AES)	-	W	160
Max Sound Pressure Level	SPL _{max}	dB SPL	114
Min. impedance modulus	Z _{min}	Ω @Hz	6.1@750
Voice-coil inductance @ 1kHz	Le _{1k}	mH	0.512
Voice-coil inductance @ 10kHz	Le _{10k}	mH	0.210
BL product	BL	N/A	8.8
Moving mass	Mms	kg	0.0091

Thiele-Small parameters

Resonance frequency	Fs	Hz	150 (\pm 30)
DC Resistance	Re	Ω	5.3 (\pm 0.5)
Mechanical quality factor	Qms	1	4.29
Electrical quality factor	Qes	1	0.59
Total quality factor	Qts	1	0.52
Suspension compliance	Cms	10 ⁻⁶ .m/N	120
Effective piston area	Sd	m ²	0.0150
Equivalent Cas air load	Vas	m ³	0.0039
Max linear excursion	Xmax	mm	\pm 2.0
Linear displacement volume	Vd	10 ⁻³ .m ³	0.0299
Reference efficiency	η_0	%	2.1
Unity load volume	Vas.Qts ²	10 ⁻³ .m ³	1.0

Absolute maximum ratings

Short term max. input voltage	Vmax	V	70
Max.excursion before damage	Xdam	mm	\pm 4.0
Ambient operating temperature	Ta	$^{\circ}$ C	-10 to +50
Storage temperature		$^{\circ}$ C	-20 to +70
Environmental withstanding			Humidity proof

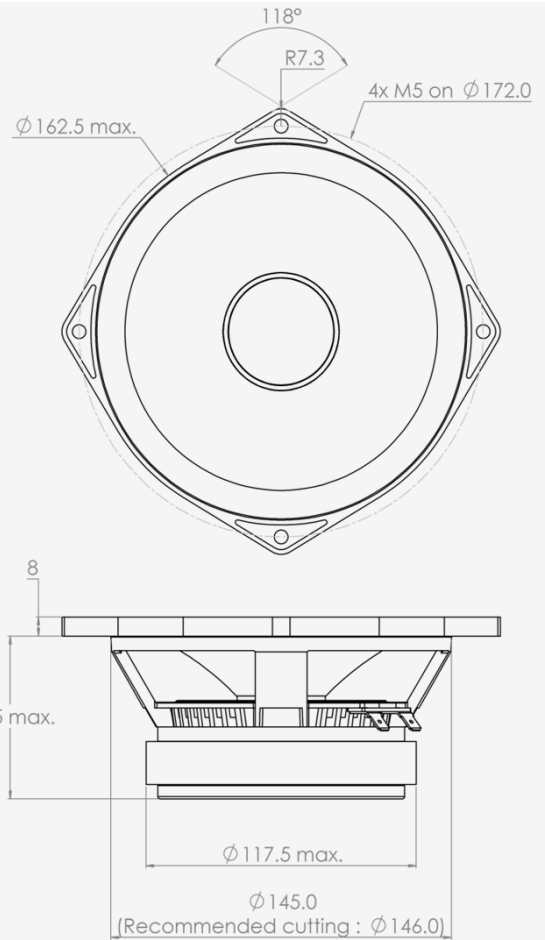

Mounting information

Air volume occupied by the driver	10 ⁻³ .m ³	0.46
Speaker net mass	kg	2.15
Baffle cut-out diameter (front mounting)	mm	146.0
Bolt number & Metric diameter	-	4x M5
Bolt circle diameter	mm	172.0
Max overall dimension (on ears)	mm	187.5
Max overall dimension (out of ears)	mm	162.5
Flange height	mm	8.0
Max magnet diameter	mm	117.5
Max depth (front mounting)	mm	68.5
Recommended reflex box	Lts / Hz	-
Electrical connection		6.35x0.8 FAS



1040

6.5 inches midrange driver

SPL curves measured on CEI standard baffle :

- . at 25 cm, normalised 1 m
- . at 1 m for reference
- . Graph amplitude = 60 dB (PHL Audio standard)

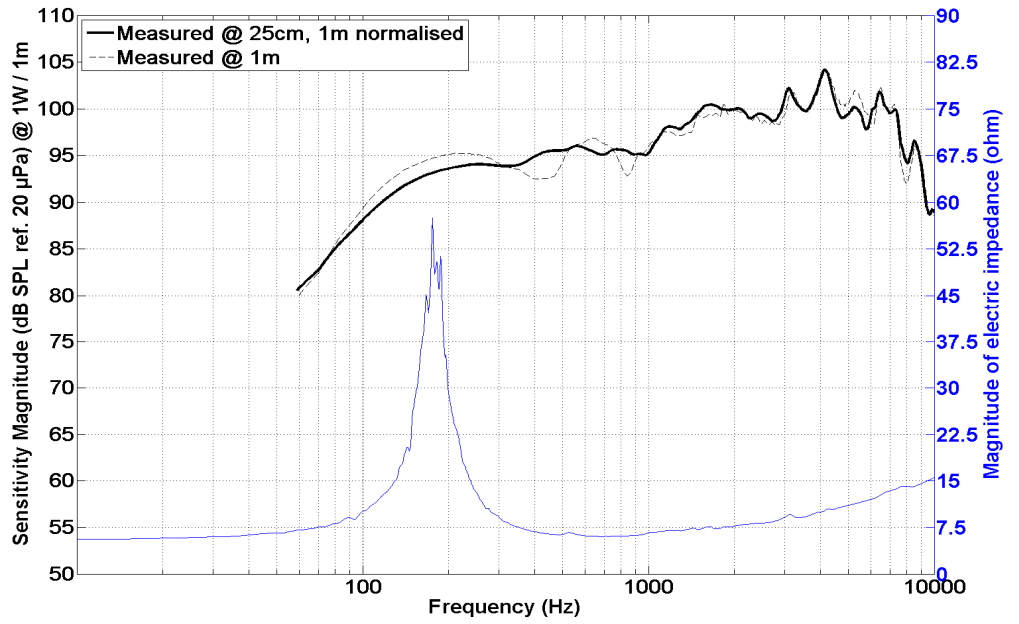

HD curve measured on CEI standard baffle :

- . at 1 meter
- . at power = $P_{AES} / 4$
- . Graph amplitude 0.01 % to 100 % (PHL Audio standard for $P_{AES}/4$)

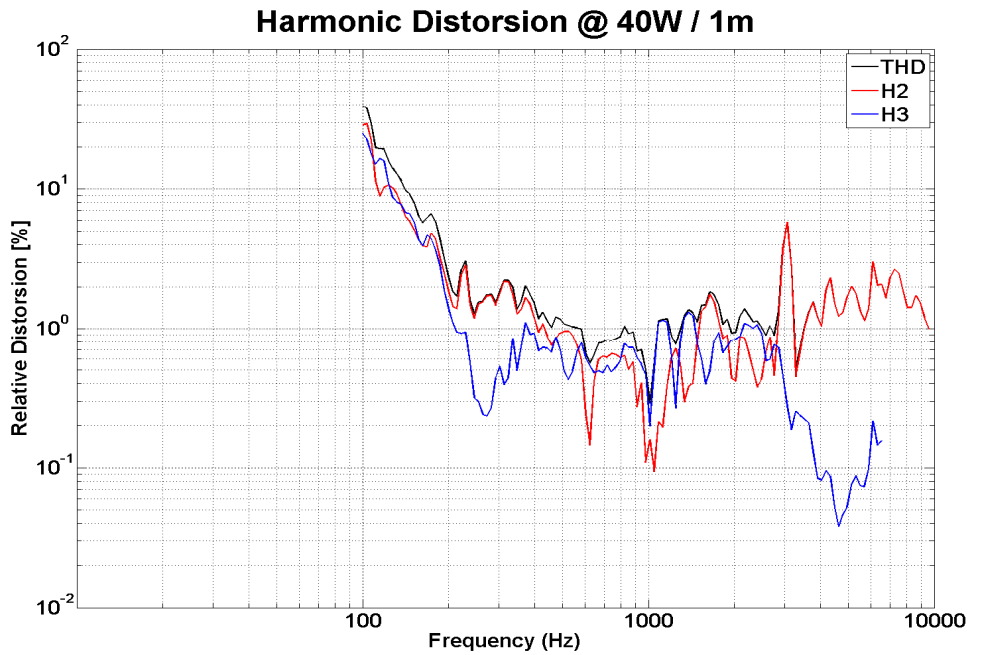

Non linear curves measured thanks to Klippel software and hardware, in free air

