

- 2" voice coil Kapton former
- Ferrite magnet circuit
- Ventilated voice coil to reduce power compression
- 94.5 dB sensitivity



Specifications	
Nominal Diameter	209mm (8")
Nominal Impedance	8Ω
Rated Power AES ⁽¹⁾	130W
Continuous Program Power ⁽²⁾	260W
Sensitivity @ 1W/1m ⁽³⁾	94.5dB
Voice Coil Diameter	50mm (2")
Voice Coil Winding Depth	11mm
Magnetic Gap Depth	8mm
Flux Density	1.00T
Magnet Weight	810g
Net Weight	2.8kg

Thiele & Small Parameters ⁽⁴⁾			
Re	6.06Ω	Fs	66.5Hz
Qms	2.58	Qes	0.40
Qts	0.35	Mms	20.3g
Cms	282μm/N	Bxl	11.30Tm
Vas	18.2l	Sd	213.8cm ²
X max ⁽⁵⁾	+/-3.2mm	X var ⁽⁶⁾	+/-6.0mm
η ₀	1.28%	Le (1kHz)	0.88mH

Constructive Characteristics	
Magnet	: Ferrite
Basket Material	: Pressed Sheet Steel
Voice Coil Winding Material	: Copper
Voice Coil Former Material	: Kapton
Cone Material	: Paper
Cone Treatment	: No
Surround Material	: Treated Cloth
Dust Dome Material	: Solid Paper

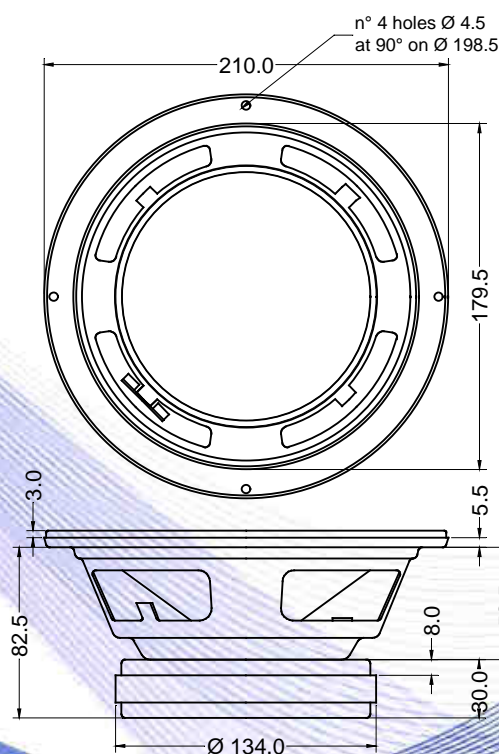

Frequency Response on IEC Baffle (DIN 45575) @ 1W,1m – Free Air Impedance

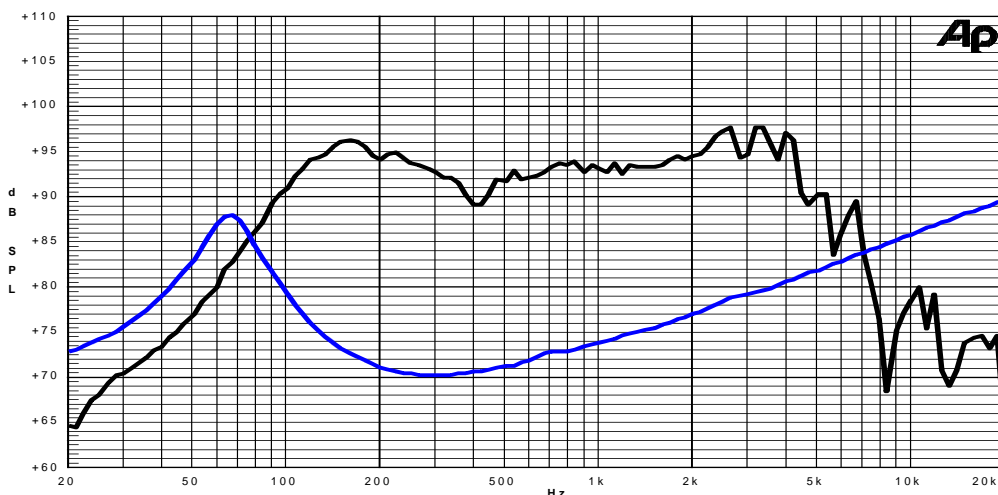

- Note:
- 1 : Rated Power measured with 2 hours test with pink noise signal, 6dB crest factor, loudspeaker mounted on enclosure
 - 2: Power on Continuous Program is defined as 3 dB greater than the Rated Power
 - 3: Calculated by Thiele & Small parameters
 - 4: Thiele & Small parameters measured with laser system without preconditioning test
 - 5: Measured with respect to a THD of 10% using a parameter-based method
 - 6: Value corresponding to a decay of the Force Factor, or Compliance, or both, equal to the 50% of the small signal value.
 - 7: Drawing dimensions: mm
 - 8: The notch around 400Hz on the frequency response is typical of the measurement on IEC baffle